

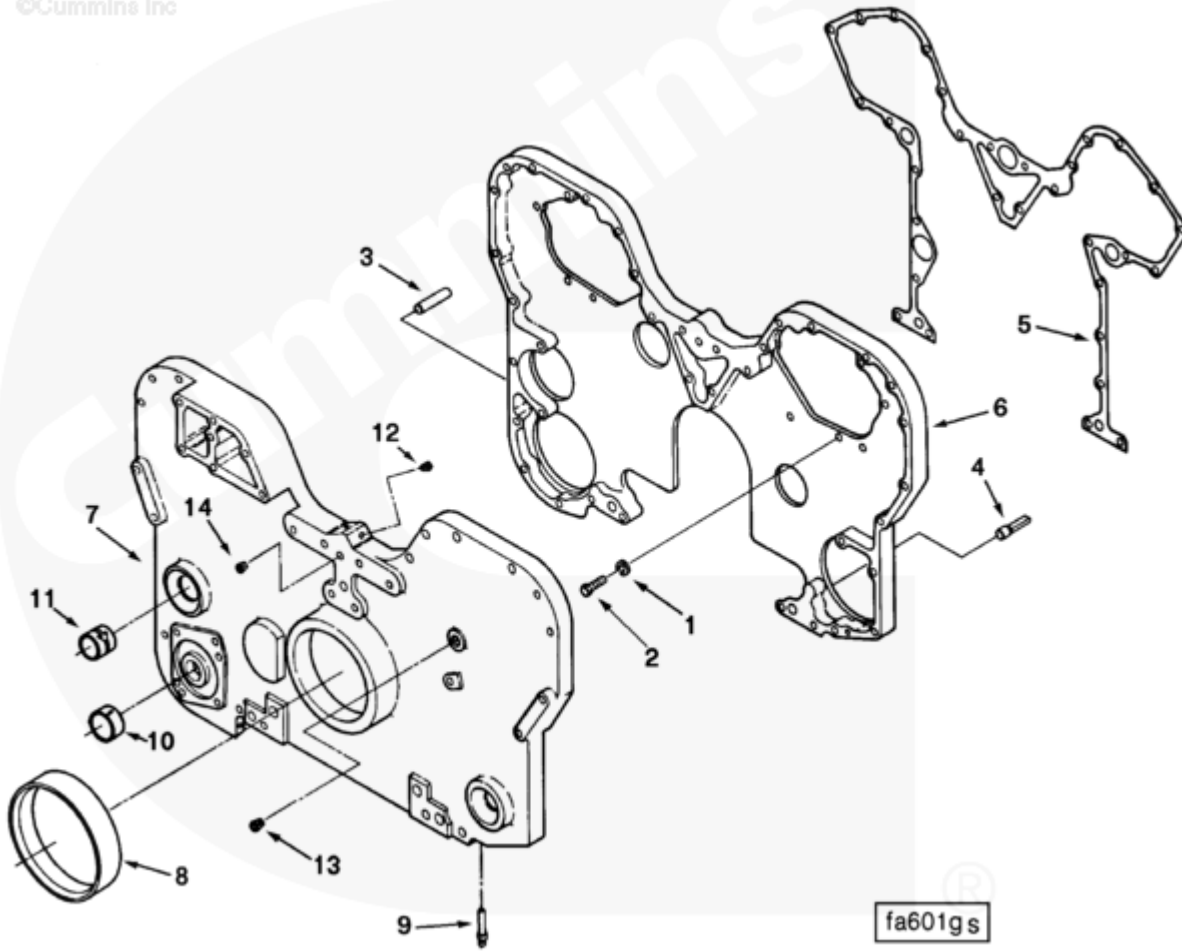

Parts Catalog - Option Detail

Electronic Parts Catalog - Option Detail				
Option	Group	Graphic	Film Card	Date
FA6719-01	01.06	fa601gs	K38	25-FEB-95
Engines	GTA38, K38, KTA38GC CM558, QSK38 CM2150 K106, QSK38 CM2150 MCRS, QSK38 CM850 MCRS			

©Cummins Inc



[SMALL](#) | [MEDIUM](#) | [LARGE](#)

Cart	Ref No	Part Number	Part Description	Required	Remarks
View My Cart					
		FA6719-01	Gear Cover And Housing		Front gear cover and gear...(More)
					housing for use with front
					hydraulic pump drive
					provisions, and without sea

					water pumps. Special for
					Hitachi only.
<input type="checkbox"/>	1	S 610	Lock Washer	15	7/16 in.
<input type="checkbox"/>	2	103009	Hexagon Head Cap Screw	8	7/16 - 14 X 1 1/4 in.
<input type="checkbox"/>	3	138912	Pin Dowel	1	
<input type="checkbox"/>	4	3176618	Diamond Dowel	1	
<input type="checkbox"/>	5	3178076	Gear Housing Gasket	1	
<input type="checkbox"/>	6	3176918	Gear Housing	1	
<input type="checkbox"/>		3069027	Gear Cover	1	
	7	3627026	Gear Cover	1	
<input type="checkbox"/>	8	205683	Bushing	1	
<input type="checkbox"/>	9	3176649	Tamper Proof Seal	6	
<input type="checkbox"/>	10	3177509	Bushing	1	
<input type="checkbox"/>	11	3177510	Bushing	2	
<input type="checkbox"/>	12	3628605	Pipe Plug	2	1/4 - 18.
<input type="checkbox"/>	13	3628606	Pipe Plug	1	1/2 - 14.
<input type="checkbox"/>	14	3628609	Pipe Plug	1	3/8-18.